

產品分類

EKC / EKJ : 浸漬式冷卻機
Cooler for Grinding liquid/Cutting liquid Machine

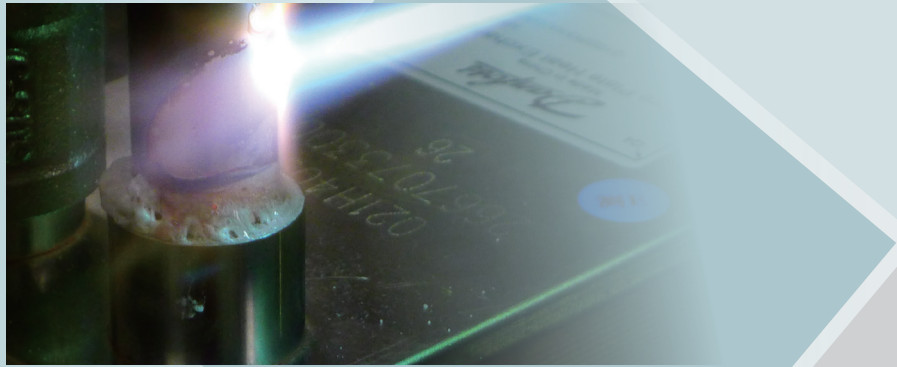

EKC/EKJ series

浸漬式冷卻機



EKC/EKJ series

浸漬式冷卻機



使用類別

- 研磨機、切削機、紙帶過濾器...等切削冷卻液。

用途功能

- 提高加工速度、保持加工液的穩定性，增加使用壽命。
- 防止油溫升高，確保加工件品質。

功能特性

- 浸漬型設計可免除液體循環系統堵塞之困擾。
- 防止液體變質。

USAGE CLASSIFICATION

- This model is designed to cool down the dielectric fluid for all kinds of Grinding/Cutting liquid and Paper filter machines...etc.

FUNCTIONS

- Advance the speed and maintain of processing liquid stability to prolong lifetime of machine.
- Prevent the temperature rise and advance the quality of process.

FEATURES

- Designed of open coil type heat exchanger can prevent the obstruction problem of liquid circulation system.
- Prevent the deterioration of liquid.

配管規格(可依客戶需求接受特殊訂製)
電 源：3 Φ AC 220V 50/60Hz 相位、電壓可依客戶需求接受特殊訂製
設定溫度：25°C~40°C 設定溫度範圍可依客戶需求接受特殊訂製
冷 媒：R-134a / R-407C / R-410A 冷媒選用可依客戶需求接受特殊訂製
環境溫度：38°C 以下

Tubing standard (Can be custom-made Upon Request)
Power source: 3 Φ AC 220V 50/60Hz Voltage Can be custom-made Upon Request
Set Temperature: 25°C~40°C
Refrigerant: R-134a / R-407C / R-410A Refrigerant Selection Can be custom-made Upon Request
Ambient Temperature: 38°C Under

標準能力規範表

型號 / 規格 Spec / Model		EKC-80	EKC-120	EKC-180	EKC-240	EKC-360	EKC-600
冷卻能力 Cooling Capacity (50/60Hz)	BTU/hr	6667/8000	10236/12283	15000/18000	20000/24000	30000/36000	50000/60000
	KCAL/hr	1680/2016	2579/3095	3780/4536	5040/6048	7560/9072	12600/15120
	W	1952/2342	2997/3596	4392/5270	5856/7027	8784/10541	14640/17568
電源 Power	Ph/V/Hz	AC 3 Φ 220V 50/60Hz ~*					
溫度控制 Temp Control	1	Fixed Temperature 定溫控制：10°C~40°C					
	2 & 3	Differential Temperature 室溫同調(機體)：±10°C					
使用溫度範圍 Use range of temperature	環境溫度 Ambient Temp	10°C~40°C					
	液體溫度 Liquid Temp	10°C~40°C					
總負荷電流 On-load Current	A	3.3	5.7	9.8	10.6	13.8	25
冷媒 Refrigerant	—	R-407C / R-410A				R-407C	
外型尺寸 Dimensions (WxDxH**)	mm	530x500x1025	530x500x1075	710x684x1265	710x684x1265	810x684x1307	880x950x1780
重量 Weight	Kg	60	70	120	150	180	310

* 非標準電壓，請洽詢業務。

* Different voltage is available, please specify upon request

**H：不含輪子及吊環高度。

**H：Height does not include wheels and rings

EKC-80/120/180/240 浸漬式水冷卻機

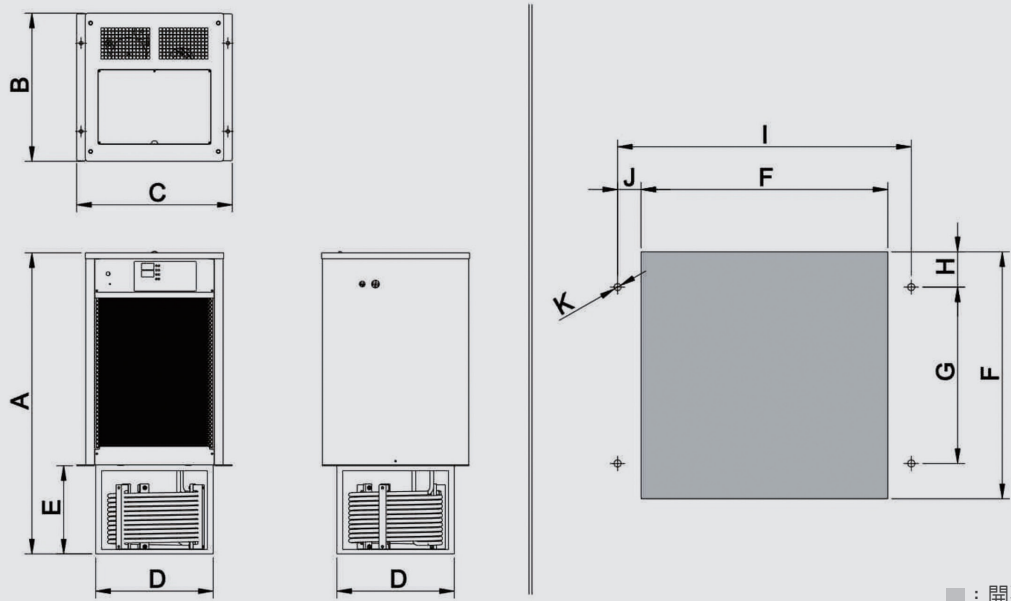

■ : 開孔尺寸圖

尺寸mm型號	A	B	C	D	E	F	G	H	I	J	K
EKC-80	1024	504	530	400	300	420	300	60	500	40	Ø12
EKC-120	1074	504	530	400	350	420	300	60	500	40	Ø12
EKC-180	1264	684	740	600	420	620	480	70	665	45	Ø12
EKC-240	1264	684	740	600	420	620	480	70	665	45	Ø12

EKC-360 浸漬式水冷卻機

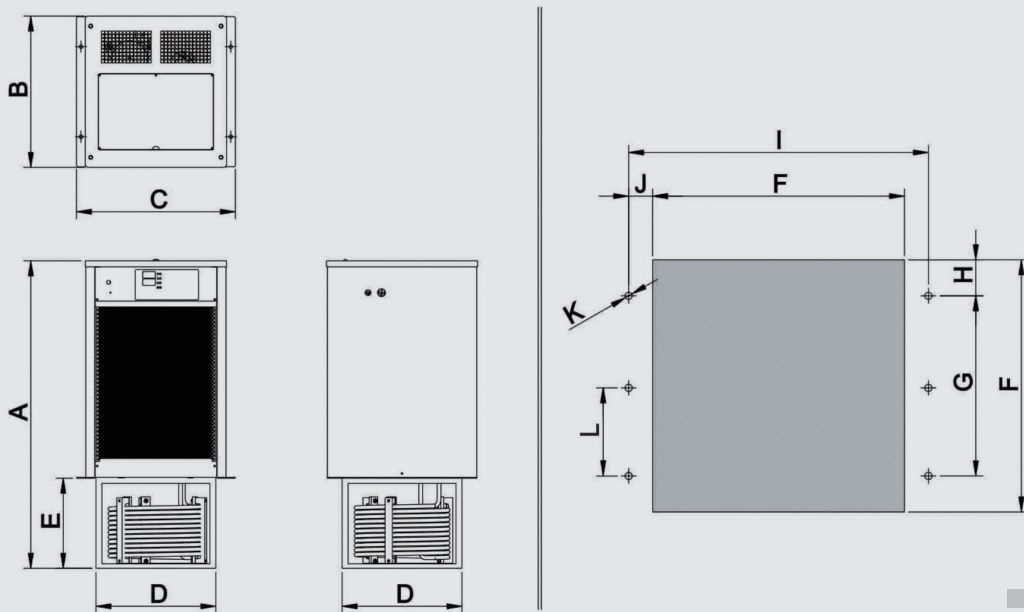

■ : 開孔尺寸圖

尺寸mm型號	A	B	C	D	E	F	G	H	I	J	K	L
EKC-360	886	684	810	650	420	590	490	50	780	50	Ø10	245